

Datasheet

Rare-gas-filled insulation spark gaps

Flexible mounting

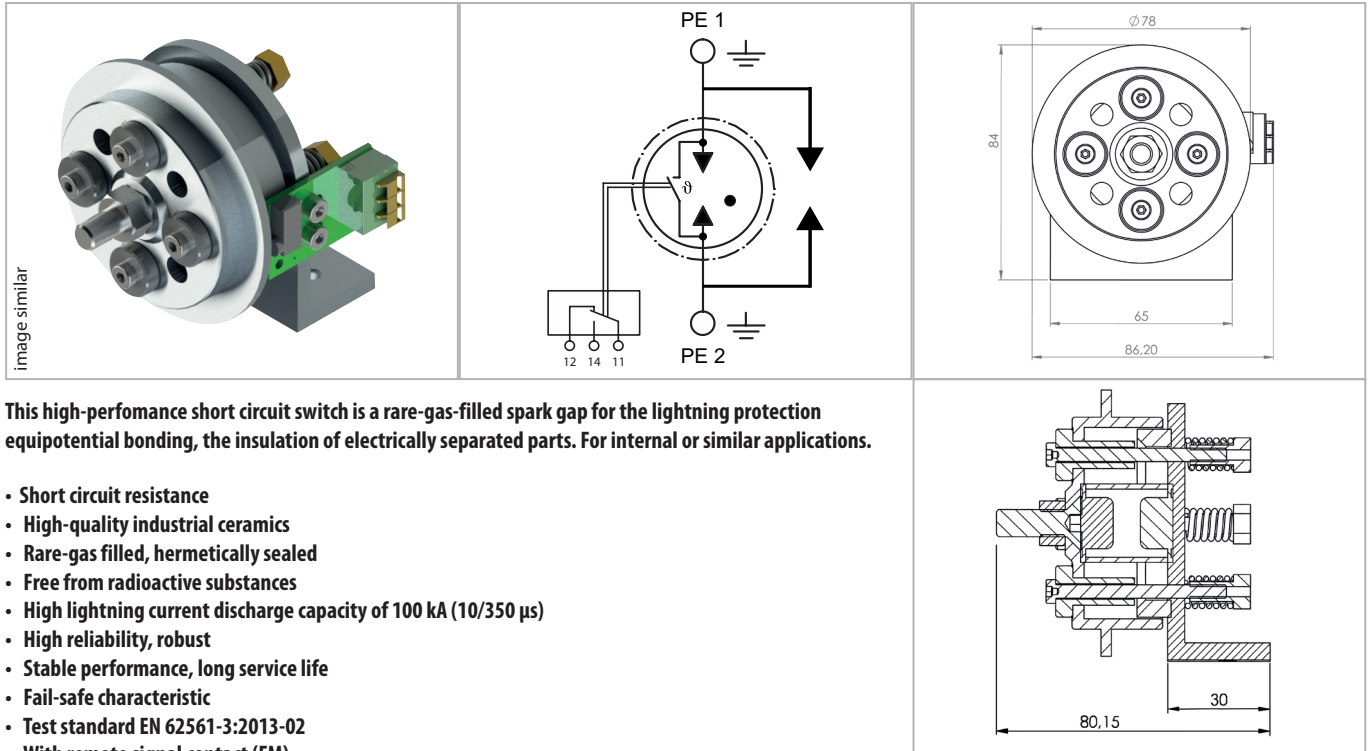

This high-performance short circuit switch is a rare-gas-filled spark gap for the lightning protection equipotential bonding, the insulation of electrically separated parts. For internal or similar applications.

- Short circuit resistance
- High-quality industrial ceramics
- Rare-gas filled, hermetically sealed
- Free from radioactive substances
- High lightning current discharge capacity of 100 kA (10/350 μ s)
- High reliability, robust
- Stable performance, long service life
- Fail-safe characteristic
- Test standard EN 62561-3:2013-02
- With remote signal contact (FM)

Technical Data		HSCS-500-FM
IEC category		Class H
Nominal DC sparkover voltage at 100 V/s	UagN	500 \pm 15% V=
Nominal AC sparkover voltage (50 Hz)	Uaw	350 \pm 15% V
Typical impulse sparkover voltage	Uas	950 V
Max. impulse sparkover voltage	Uas	1300 V
Lightning impulse current (10/350 μ s) total	I _{total}	100 kA
Nominal impulse discharge current (10 x 8/20 μ s)	I _n	100 kA
5x Nominal alternating discharge current at 50 Hz, 1 s, 3 min pause	I _{wn}	100/1 A/s
Nominal alternating discharge current (50 Hz)		200/0,5 A/s
Spark-gap extinguishing conditions	V _{ex}	<230 V / <100 A
Insulation resistance at 10 V, 100 V		>1 G Ω
Short-circuit current rating	ISCCR	7,2 kA r.m.s./300 ms
Self-capacitance at 1 kHz		4 pF
Test category/climatic category		DIN IEC 60068-1 / 40/90/21
Relative humidity		10%...95% rh
Degree of protection (IEC EN 60529)		IP 20
Operating temperature range	TU	-40 - +80 °C
Terminals		M8 bolt/nut (NIROSTA stainless steel)
3x lightning impulse current (10/350 μ s), long-duration current (CENELEC/BTTF 62-2)	I _{imp}	75 kA / 38 As / 1,45 MJ/ Ω + 150 A/0,5 s/75 As
20x lightning impulse current (10/45 μ s) half-wave (DIN 48810)		60 kA/10 As/0,1 MJ/ Ω

Order Data

Product	HSCS-500-FM
Article-No.	48 78 08