

Surge protection of power supply

Lightning current arrester type 1 for AC power supplies / IsoPro

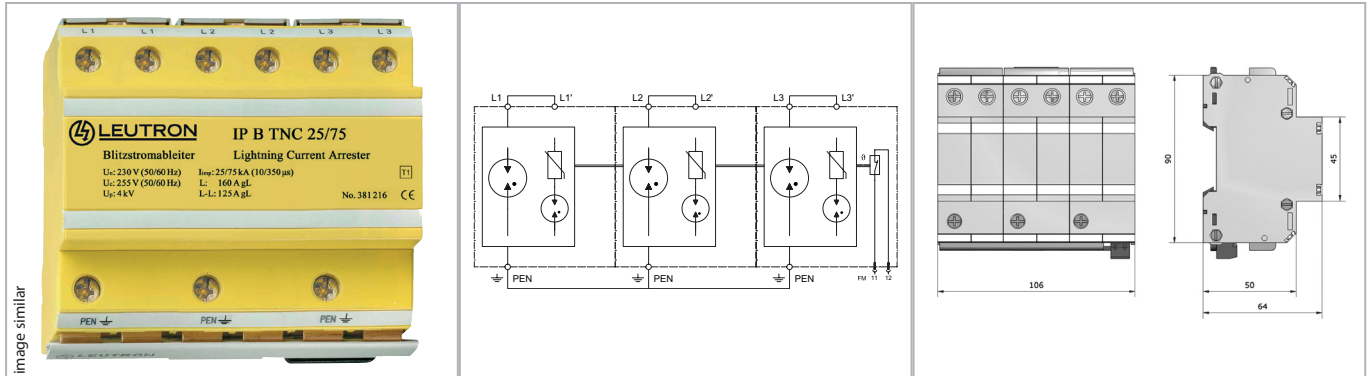

Multi-pole lightning current arrester for 3-phase TN-C systems. The arresters can be installed at the transition OA to 1 according to the lightning protection zones concept.

- Test standard: IEC 61643-11 / EN 61643-11
- Lightning current arresters type 1 (class I)
- Rare-gas-filled spark gap, hermetically sealed
- High insulation resistance
- Degree of protection according to IEC EN 60529: IP 20
- Inflammability class according to UL 94 V0
- Mounting on 35 mm DIN rail (EN 60715)
- EAC certification
- All-in-one protection unit, ready for connection
- Remote signalling contact: break contact

Technical Data	IP B TNC 25/75/FM	
IEC category		Type 1
Nominal voltage AC	UN	230/400 V~
Max. continuous operating voltage AC (50/60 Hz)	Uc	255 V~
Insulation resistance	Risol	>10 GΩ
Protection level at 100% lightn. imp. sparkover voltage (1.2/50 μs)	Up	≤ 4,0 kV
Protection level	Up	≤ 4,0 kV
Response time	tA	<50 ns
Lightning impulse current (10/350 μs) total	I _{total}	75 kA
Lightning impulse current (10/350 μs) L-N/N-PE/L-PEN	I _{imp}	- / - / 25 kA
Short-circuit withstand capability at max. back-up fuse	I _k	50 kA _{eff}
Max. acceptable back-up fuse F2 (spur wiring)		160 A gG
Max. acceptable back-up fuse F1 (serial wiring)		125 A gG
Operating temperature range	TU	-40 - +80 °C
Max. conductor cross section		stranded 50/fine stranded 35 mm ²
Recommended conductor cross section		25 mm ²
Max. connection torque for terminals		4,0 Nm
Enclosure material / colour		polycarbonate (halogen-free) UL 94-V0 / yellow
Switching capacity FM		250 V/2 A
Max. conductor cross section FM		1,5 mm ²
Max. locking torque FM terminals		0,25 Nm

Order Data

Product	IP B TNC 25/75/FM
Article-No.	38 12 17